

PELLETING PRESS

TYPE PALADIN 1600ES/BM



Pelleting section – general description

The Paladin is of a sturdy, self contained design, with a combined V-rope and toothed belt transmission, provided through a balanced twin drive system. The design of the mainshaft allows applying of maximum torque on the pelleting section. These features make the Paladin Pelletmill range a universal adaptable machine whereby maximum reliability is provided under all working conditions.

Twin Drive

The twin drive ensures a smooth operation with low levels of vibrations. Lifetime of mainshaft is ensured because of the symmetrical load due to the two intermediate shafts driving the main toothed wheel. The die-speed is chosen based on the application. In case adjustment of speed is required the easy accessible pulleys can be changed.

Hydraulic system for Twin-Drive and Brake on Mainshaft

The V-belts of the two drives from the main motors are automatically tensioned with hydraulic cylinders. This system is also used to fixate the mainshaft with a special designed brake system. In the event that the mainshaft is turned due to overload it takes minimum downtime to position it in the original position. It also allows the operators to position the rollers in other positions for maximum efficient feed-distribution.

Symmetrical Die with tapered fit

The Paladin vertical ring-dies are all fully reversible. The correct number of bolts is applied for having a very sturdy fit which easily can be (dis)mantled.

Pelleting Chamber

For reducing the noise level all paladin doors are doubled skinned. The inlet has a pneumatic operated bypass which can be used for overload protection as well. Each paladin is standard equipped with an adjustable knife assembly. The roll-head is either in 2- or 3-roll design depending on the application. Through 40 years of experience the design of the front-plate has lead to a system with deflectors ensuring maximum feed-distribution.

Electrical system

The paladin is equipped with all necessary switches and sensors to allow a safe controllable operation of the machine. Except for the two Main-motors all of the electrical items in the Paladin are connected centrally into one Box.

Hoist for exchanging dies and rollers

The paladin standard equipped with a heavy duty retractable bar inside the housing. When rollers and/or dies are in need of exchange they can be lifted easily with the special tools. By means of loosening the brake on the mainshaft the rollers can easily be positioned centrally below the hoist.

Accessories:

- Electric motors
- Set of tools
- Rolls with profile suiting the application
- Automatic greasing with flow control
- Electro pneumatically controlled grease lubrication system

PELLETING PRESS

TYPE PALADIN 1600ES/BM

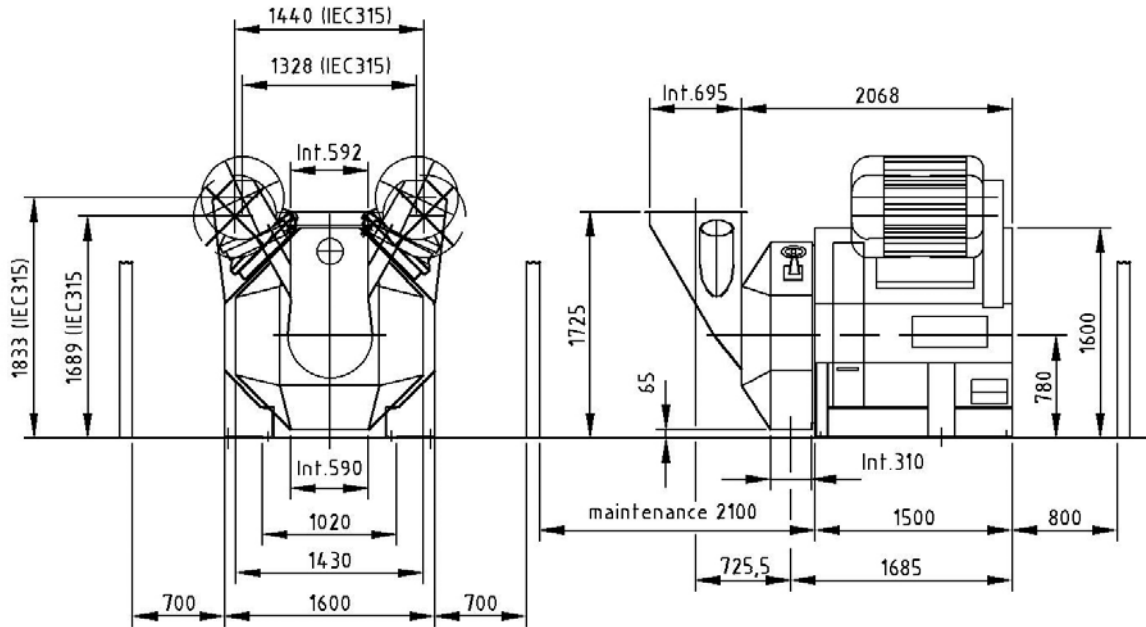

Dimensions in mm.

Technical data

Die Dimensions	
Die track diameter	850 mm
Width of die track	175 - 210 mm
Die speed	4,7 - 6,7 m/sec

Standard finishes:		
Press	Cream	RAL 1015
Guards	Blue	RAL 5017
Motors (if supplied with press)	Blue	RAL 5017

Main drive motors *)	
Number	2
Maximum power, each	110 kW
Speed	1500 rpm

Weights:		Max
Press with rolls		60 kN
Die		6 - 8 kN
Motors		14 - 18 kN
Static weight including motors		80 - 86 kN
Dynamic weight including motors		105 - 130 kN

Hydraulic oil pump	
Motor power	0,37 kw
Speed	900 rpm

External dimensions of packing:	
Length	3100 mm
Width	2400 mm
Height	2100 mm

ANDRITZ FEED & BIOFUEL A/S
Denmark
Tel. +45 72160 300
andritz-fb.dk@andritz.com

ANDRITZ FEED & BIOFUEL B.V.
The Netherlands
Tel. +31 40 2627777
andritz-fb.nl@andritz.com

ANDRITZ FEED & BIOFUEL,
Division of Andritz S.A.S., France
Tel. 33247506364
andritz-fb.fr@andritz.com

ANDRITZ FEED & BIOFUEL Ltd.
England
Tel. +44 1482825119
andritz-fb.uk@andritz.com

ANDRITZ FEED & BIOFUEL
eine Zweigniederlassung der Andritz GmbH.
Germany
Tel. +49 2104 9197-0
andritz-fb.de@andritz.com

ANDRITZ FEED & BIOFUEL
Division Of Andritz Inc. USA
Tel. +1 570-546-1253
andritz-fb.us@andritz.com

ANDRITZ FEED & BIOFUEL
Rep. Office Venezuela
Venezuela
Tel. +58 241 8422515
andritz-fb.ve@andritz.com

ANDRITZ FEED & BIOFUEL,
Division of Andritz Hydro S.A. de C.V.
Mexico
Tel. +52 (229) 178 3669
andritz-fb.mx@andritz.com

ANDRITZ FEED & BIOFUEL Brasil Ltda.
Brasil
Tel. +55 51 3333 0128
andritz-fb.br@andritz.com

ANDRITZ FEED & BIOFUEL
Division of Andritz Chile Ltda.
Chile
Tel.: +56 2214 5711
andritz-fb.cl@andritz.com

ANDRITZ FEED & BIOFUEL
Division Of Andritz Pty Ltd.
Australia
Tel. +61 3 8795 9800
andritz-fb.au@andritz.com

ANDRITZ FEED & BIOFUEL
Rep. office Vietnam
Tel.: +84 8 6253 9434
andritz-fb.vi@andritz.com

ANDRITZ FEED & BIOFUEL
Division Of Andritz Technologies Ltd.
P.R. China
Tel: +86 21 64670285
andritz-fb.cn@andritz.com